

Visualization of Aerodynamic Effects on a Double-delta Wing Aircraft Model using Pressure Sensitive Paint (PSP) Technique

Klein, C.* and Engler, R. H.*

* DLR-Göttingen, Aerodynamics and Flow Technology, Bunsenstr. 10, D-37073 Göttingen, Germany.

Received 25 January 1999.
Revised 14 May 1999.

Abstract: Visualization of aerodynamic effects on a three-dimensional double-delta wing aircraft model was conducted using an optical pressure measurement system, based on the Pressure Sensitive Paint (PSP) technique, and in addition a laser-light sheet method. The combination of PSP technology with the laser-light sheet method, provides a good understanding of the flow around the wind tunnel model. In recent years, this novel PSP-technology has attracted considerable attention in the aerospace community. The PSP technique can be used to realize absolute pressure measurements on a surface of a model and in addition to evaluate quantitative aerodynamic flow phenomena using a scientific grade camera and image processing techniques. The PSP system was tested in the Transonic Wind Tunnel of the German Aerospace Center in Göttingen (TWG) under real flow conditions. Instantaneous pressure distributions are recorded in almost real-time so that the recognition and analysis of the vortex dynamics on the model surface is possible. Even the vortex breakdown process, as well as the fine structured Kelvin-Helmholtz instabilities and secondary vortex structures, can be detected by this measurement technique.

Keywords: Pressure Sensitive Paint (PSP), transonic flow, double-delta wing model, vortex structures, vortex breakdown, Kelvin-Helmholtz instabilities.

Nomenclature:

I	photoluminescence intensity
K_q	quenching constant
PO_2	partial pressure of oxygen
p	local static pressure
A, B, C	calibration coefficients of a paint
t	response time
l	thickness of the binder layer
D	diffusion coefficient of oxygen
A	aspect ratio
0	absence of oxygen (vacuum conditions)
ref	reference condition

1. Introduction

The physical basis of all PSP formulations is the oxygen-quenching phenomenon in which excited organic molecules are deactivated by oxygen. For this reason, the pressure sensitive molecule is excited by an appropriate light source and the luminescence intensity of the pressure sensitive molecule emission can be related to the

oxygen concentration, which is proportional to the local static pressure [1].

The determination of a two-dimensional pressure distribution on the surface of an aircraft model by using a luminescent paint is an advance in the field of non-intrusive measurement techniques in aerodynamics. The PSP method gives qualitative as well as quantitative pressure images of the observed model surfaces [2], without any disturbance of conventional pressure tap measurements, that can influence the flow over the entire surface of a wind tunnel model and introduce measurement errors. Therefore, this method could be used on model surfaces for flow visualization [3] and it can also be used to provide detailed aerodynamic information about the model aerodynamics [4].

The presented results were obtained during investigations with the PSP method on a three-dimensional double-delta wing model with sharp leading edges.

2. PSP Basis

PSP techniques are based on the deactivation of photochemical-excited organic molecules, so called luminophores, by oxygen molecules. This oxygen-quenching process of luminescence was first discovered and described by Kautsky and Hirsch [5] in 1935 and will be briefly reviewed here.

A luminophore is shifted to an excited electronic state (singlet) by absorbing a photon of appropriate energy. This excited luminophore can leave the higher energy level and return to the ground electronic state by emitting a photon (photoluminescence) or with no photoemission (e.g. intercombination). An alternate but also radiationless transition of an excited luminophore to the ground electronic state is provided by an interaction (collision) with an oxygen molecule. That means, that the excess energy of the luminophore is absorbed by the oxygen during the collision, and that the oxygen molecule becomes excited (in a non-stable energy state). This photophysical process is called oxygen-quenching. The interaction of excited luminophores with oxygen molecules increases the probability of a radiationless process. Therefore the photoluminescence decreases, if in a given volume the number of oxygen molecules increases. This behavior of photoluminescence of a luminophore when exposed to oxygen molecules can be described by the Stern-Volmer relation either for the photoluminescence lifetimes itself (lifetime-method) [2], or for the detected photoluminescence intensities (intensity-method) [1]. All the results presented here were obtained using the intensity-method, therefore only the Stern-Volmer equation for this method is given:

$$I_0/I = 1 + K_q P O_2 . \quad (1)$$

Here, I_0 is the photoluminescence in the absence of oxygen (vacuum), I is the detected photoluminescence, K_q is the quenching constant, and $P O_2$ is the partial pressure of oxygen. K_q is a function of temperature.

For a general pressure sensitive paint formulation, the luminophores (e.g. Ruthenium or Platinum Octaethylporphyrin "PtOEP") are located in a binder material (e.g. silicon rubber). Of course, the binder compound used must be permeable to the oxygen molecules. To calculate the static pressure values from a measured intensity distribution for such a paint formulation it is more useful to write equation (1) as

$$p = A(T) + B(T)(I_{ref}/I) + C(T)(I_{ref}/I)^2 , \quad (2)$$

where p is the local static pressure of the investigated area; A, B, C are temperature dependent calibration coefficients of the pressure sensitive paint formulation, which can be determined in laboratory or pressurized wind tunnel; and I_{ref} is the corresponding intensity value for a constant reference pressure. Thus, using a ratio of images taken at two pressure conditions ("wind on" and "wind off") allows the determination of static pressures over the surface of interest. A problem that occurs when using PSP in this intensity method is model displacement. Usually a model movement takes place when the flow is turned on because of the aerodynamic forces on the model. Thus, a transformation must be applied to realign the two images [2] to exclude the influence of model and support-sting deformation on the resulting images [6].

The diffusion process of the oxygen through the binder gives the time response of the paint. The response time t is therefore mainly controlled by the thickness l of the binder layer and can be written as

$$t \approx l^2/D, \quad (3)$$

where D is the diffusion coefficient of oxygen.

A more detailed description of different pressure sensitive paint formulations ("open PSP formulations", "binary paint") as well as a more complex theoretical background of the use of Stern-Volmer equation are presented in [7] and [8].

3. Experimental Setup

The presented measurements were performed in the Transonic Wind Tunnel of DLR Göttingen (TWG). This tunnel is a continuously driven facility that operates at Mach numbers between 0.5 and 1.2 using the $1\text{m} \times 1\text{m}$ test section with perforated walls.

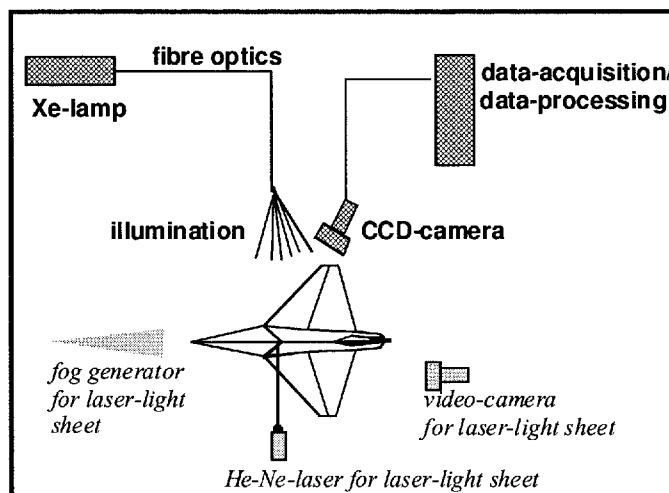

Fig. 1. Principal experimental setup for PSP and laser-light sheet measurements.

A plate element was developed especially for this test section for implementation of the excitation illuminators and camera observation, and was mounted on the upper wall of the test section. The used light source for excitation of the luminophores is a DLR-developed Xenon flash-lamp with exchangeable filters. In front of the light-output, four liquid fibre optics each 20m in length are connected. Using this light source for excitation and a scientific grade 16-bit, 512×512 -pixel CCD slow-scan camera, exposure times of approximately 1s can be realized. The aperture of the objective lenses used was chosen in such manner that a sharp image of the three-dimensional model was acquired. In parallel, an optical angle-of-attack control system gives the real angle under

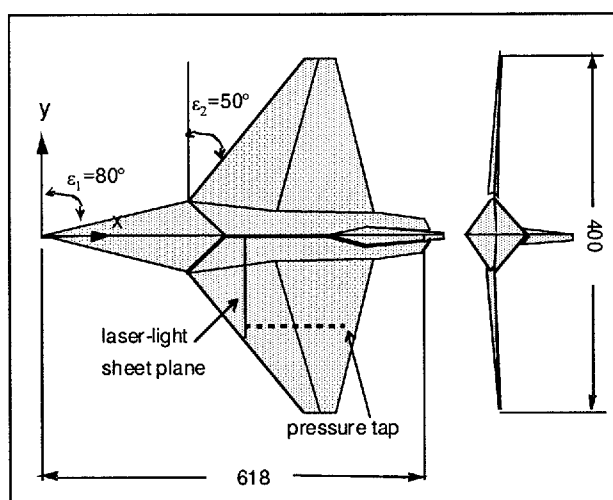

Fig. 2. Model geometry.

flow conditions in order to minimize the above mentioned model displacement and to allow, mostly in real-time, a data reduction and aerodynamic pre-interpretation. Finally, a data acquisition system obtains all of the important PSP and flow data. Figure 1 shows the general PSP system composition and the setup for the laser-light sheet measurements. These two different methods were used separately.

In Fig. 2 the geometry of the investigated double-delta wing model is given. The three-dimensional double-delta wing model has an aspect ratio of $A=1.79$ and is equipped with a lot of conventional pressure taps (PSI-technique). The section that is used for the PSP and PSI comparison is also shown in Fig. 2.

The L4 pressure sensitive paint formulation from Optrod Ltd. [9], based on pyrene as the luminophore, which had calibration coefficients $A=-0.66$, $B=7.6 \cdot 10^{-3}$ and $C=8.4 \cdot 10^{-5}$ at 20°C , was used for the presented results. This paint consists of a screen layer, adhesive layer and an active layer with a total thickness of about $50 \pm 20 \mu\text{m}$ and a response time of 0.5s.

A laser light sheet was also used to show the influence of the vortices above the model on the measured pressure distribution of the model surface.

4. Results

A typical PSP result for the investigated double-delta wing model is given in Fig. 3. The color bar gives the relationship between the shown color on the model surface and the calculated pressure coefficients ($c_p = [p - p_\infty] / q_\infty$, with p as measured pressure, p_∞ as freestream static pressure and q_∞ as freestream dynamic pressure) based on the intensity values measured with PSP. The pressure distribution in Fig. 3 shows clearly the vortex trajectories as "footprints" from the fuselage part as well as from the wing part. Vortex interactions can therefore be easily visualized by making several measurements for different angles-of-attack and Mach numbers.

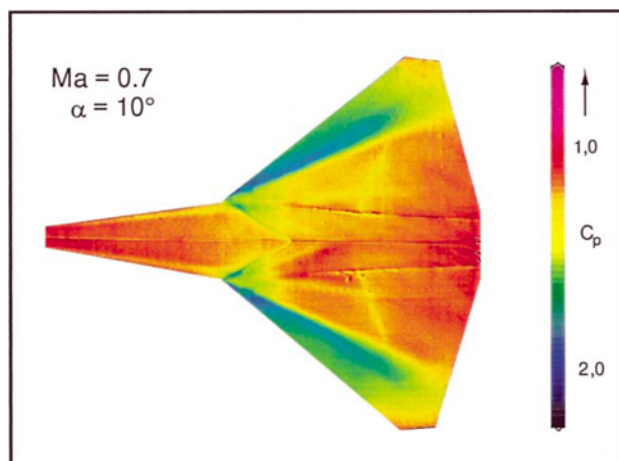

Fig. 3. c_p distribution on the model surface.

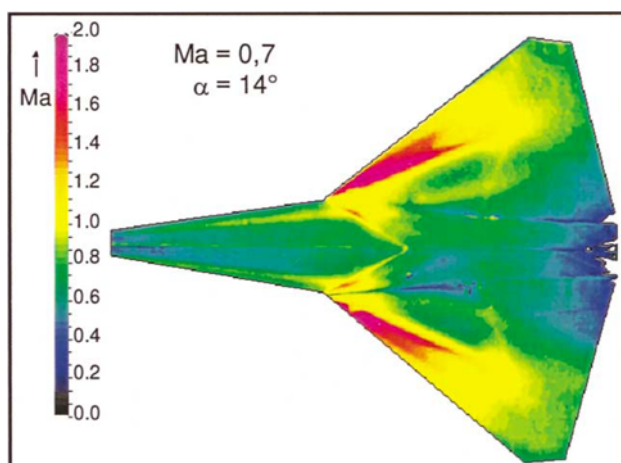

Fig. 4. Local Mach number distribution above the model surface.

Another possible presentation of PSP results is given in Fig. 4: the local Mach number (Ma) development on the model surface. The change of the local Mach number along the vortex-axis is visible as expected, but also in the region of the cockpit, there exists an unexpected area of higher Mach numbers. This effect could be visualized with PSP by simple modification of the data presentation.

The comparison in Fig. 5 of the measured pressure coefficients with the PSP technique and the conventional pressure tap technique (PSI) shows a good agreement. The average error of the absolute pressure is about ± 15 mbar with reference to the pressure tap data by the total pressure range on the model surface between 0.2-1.2 bar. A more detailed comparison of PSP and PSI data will be found in [10]. In the following, the main attention is given to the measured aerodynamic effects. As already mentioned, the recorded pressure images can be interpreted as the footprints of the vortex field near the wall. This interpretation leads to an aerodynamic understanding of the PSP images. The vortices generated from the fuselage and the wing for $Ma=0.7$ and an angle-of-attack $\alpha=14^\circ$ are clearly visible in Fig. 6.

The basic idea for a double-delta wing is that the vortex breakdown process should be decelerated by the generated vortices of the fuselage part.

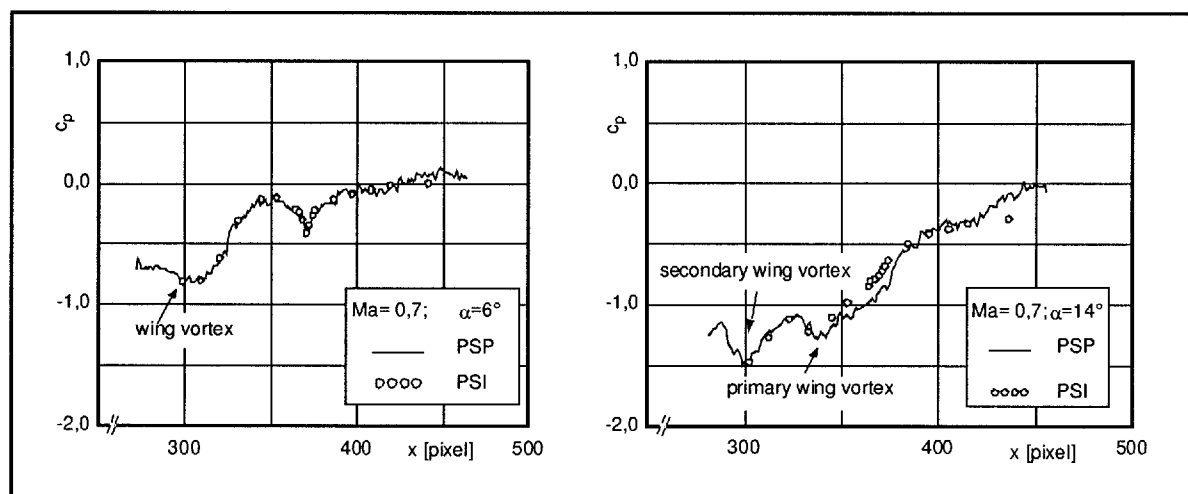

Fig. 5. c_p -coefficients for PSP and PSI results for $\alpha = 6^\circ$ and 14° along the pressure tap row.

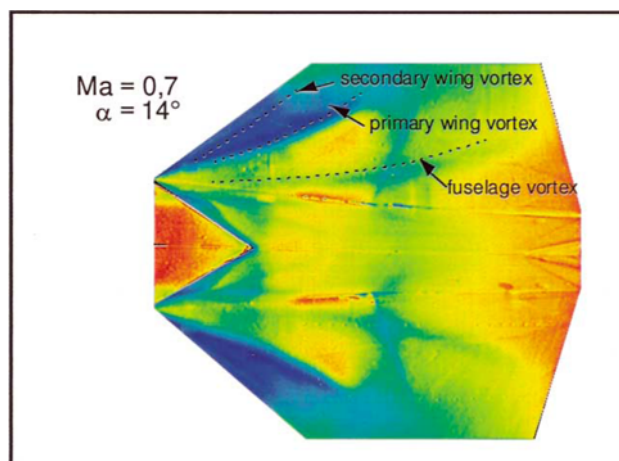

Fig. 6. Pressure-field on the model surface visualizing vortex trajectories.

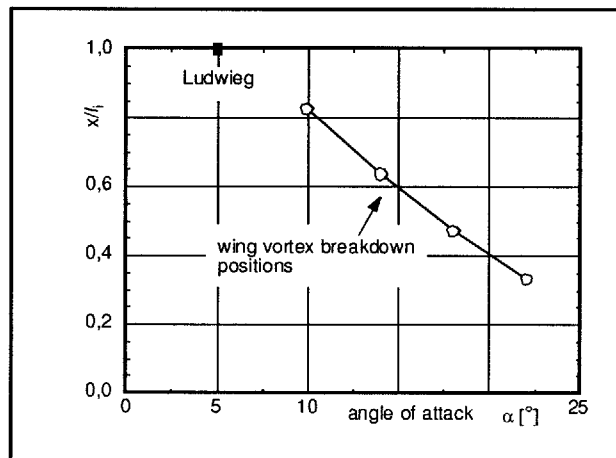

Fig. 7. Vortex breakdown position of the wing vortex.

But already the real-time PSP images show that for this model the influence of the fuselage vortices are not as strong as theoretically predicted. Therefore, it can be detected from the PSP results in Fig. 6, that the theoretical prediction of fuselage and the wing vortex merging for this double-delta wing model does not take place. Even for a higher angle-of-attack no vortex merging process was recognized. For this model the behavior of the vortex breakdown of the wing vortices is similar to the vortex breakdown of a simple delta wing with the same aspect ratio. This behavior of the vortex breakdown for the wing can be seen in Fig. 7. Here, the vortex breakdown position of the wing vortex is plotted as a function of the angle-of-attack. In this figure the theoretical prediction of Ludwig's theory for the vortex breakdown position for a flat delta wing with the same aspect ratio as the investigated double-delta wing is also given.

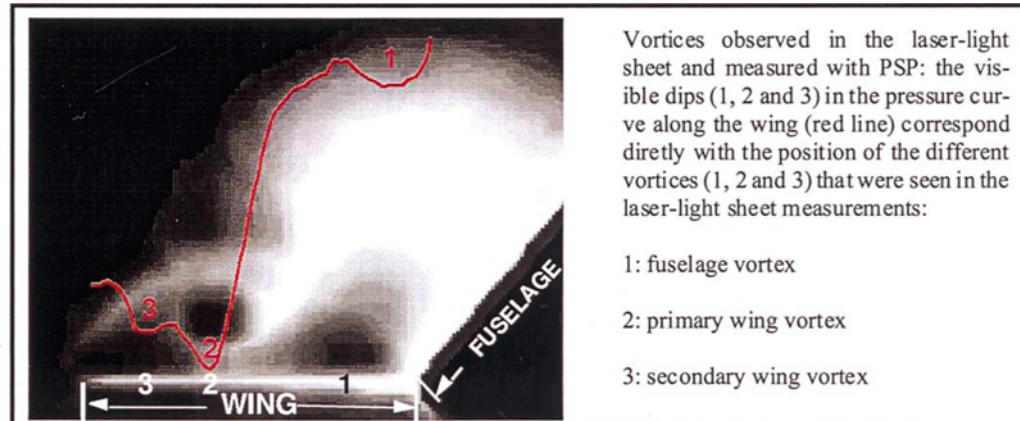

Fig. 8. Laser-light sheet and pressure distribution curve at 20% wing depth.

As well, primary and secondary vortices on the wing can be visualized (Fig. 6) from the measured pressure values with this kind of measurement technique and are also detectable from the quantitative pressure data in Fig. 5 for the same angle-of-attack. In addition, laser-light sheet measurements were performed to visualize the influence of the generated vortices above the model and their effects to the pressure distribution measured with PSP. In Fig. 8 the pressure histogram is plotted along the same section where the laser-light sheet is located for an angle-of-attack of $\alpha=10^\circ$. In this figure, the flow is out of the page. The pressure distribution (red curve) shown is that along the wing surface.

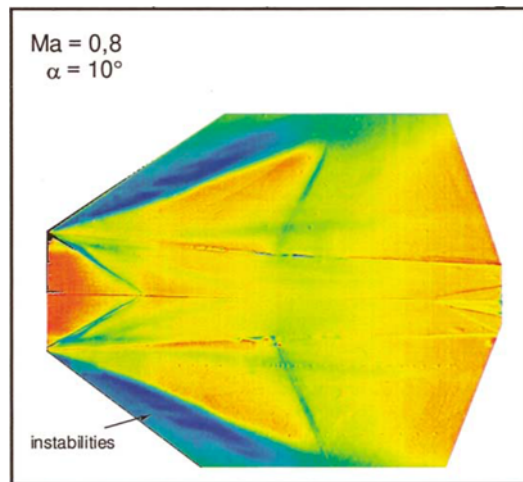
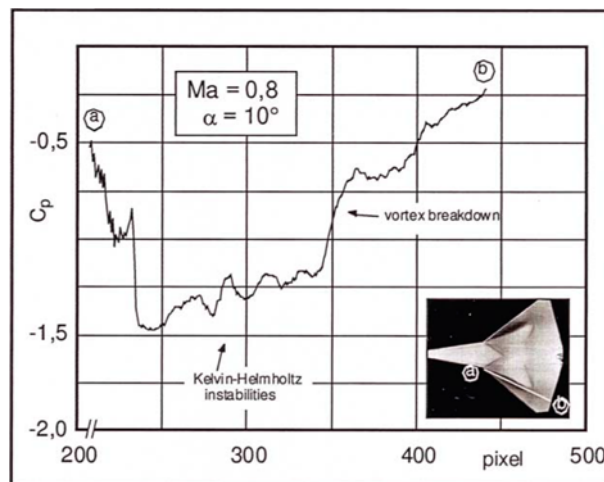

Fig. 9. Visualization of pressure instabilities.

Fig. 10. c_p distribution along the line a-b.

In this image the influence of the flow field to the absolute pressure on the models surface can be recognized. Even in the laser-light sheet the secondary wing vortex is visible.

Also, as shown in Fig. 9, Kelvin-Helmholtz instabilities of the wing vortices for $Ma=0.8$ and $\alpha=10^\circ$ can be visualized using the PSP technique. These instabilities could be quantitatively resolved from the pressure values obtained with PSP along the wing vortex. Figure 10 shows the pressure distribution along a line on the vortex axis. In this figure, two effects can be observed: the Kelvin-Helmholtz instabilities and the pressure decompression caused by the vortex breakdown [11].

5. Conclusions

The PSP technique is an excellent tool to visualize aerodynamic phenomena on a complex three-dimensional model in nearly real-time and to optimize its aerodynamic characteristics. Vortex interactions, like vortex merging and vortex breakdown, can be clearly analyzed using this two dimensional technique. Even fine structures, such as Kelvin-Helmholtz instabilities in the vortex-shear layer, and secondary-vortex structures with their influence on the pressure at the model surface, can be detected and interpreted using the described optical pressure measurement system. The combination of PSP technology with the laser-light sheet measurement system for flow-field measurements, provides a detailed understanding of the flow around a wind tunnel model.

Acknowledgments

The PSP hard- and software components were funded by the BMBF program No 20A9505T1.

References

- [1] Vollan, A. and Alati, L., A New Optical Pressure Measurement System, 14th ICIASF Congress (Rockville, MD), (1991).
- [2] Engler, R. H. and Klein, Chr., First Results Using the New DLR PSP System -Intensity and Lifetime Measurements, Conference "Wind Tunnels and Wind Tunnel Test Techniques" (Cambridge UK), (1997).
- [3] Morris, M. J., Donovan, J. F., Kegelmann, J. T., Schwab, S. D., Levy, R. L. and Crites, R. C., Aerodynamic Applications of Pressure Sensitive Paint, AIAA Journal, Vol. 31, No.3(1993), 419-425.
- [4] Engler, R. H., Hartmann, K., Troyanovski, I. and Vollan, A., Description and assessment of a new optical pressure measurement system (OPMS) demonstrated in the high speed wind tunnel of DLR in Göttingen, DLR-FB (1992), 92-24.
- [5] Kautsky, H. and Hirsch, A., Nachweis geringster Sauerstoffmengen durch Phosphoreszenztilgung, Z. f. anorg. Und allg. Chemie, Band 222, (1935), 126-134.
- [6] Le Sant, Y., Deleglise, B., Mebarki, Y. and Merienne, M-C., An Automatic Image Alignment Method Applied to Pressure Sensitive Paint Measurements, 17th ICIASF Congress (Monterey, CA., USA), (1997).
- [7] Fonov, S. D., Radchenko, V. N. and Mosharov, V. E., Luminescent Pressure Sensors in Aerodynamic Experiments, TsAGI, No. 8005.
- [8] Holmes, J. W., Optical Pressure Measurement (PSP), Presentation on Modern Optical Flow Measurement Advanced School, Udine (Italy), (October 1997).
- [9] Optrod, Luminescent Pressure Sensors, Technical Notes (1996).
- [10] Klein, Chr. Application of Pressure Sensitive Paint (PSP) for Determination of the Instantaneous Pressure Field of Models in a Windtunnel, PhD-thesis, DLR-Forschungsbericht 97-55 (1997), published in German.
- [11] Wedemeyer, E., Vortex Breakdown, High Angle of Attack Aerodynamics, AGARD CP 121 (1982), 9-1/9-17.

Authors' Profiles



Christian Klein: He studied physics at the University of Göttingen and joined for his diploma work the Max-Planck Institute for Fluid Mechanics in Göttingen. The diploma work was an experimental investigation of turbulent channel flow using LDV. He received his diploma degree in 1994. For his following Ph.D. thesis, he investigated the application of Pressure Sensitive Paint (PSP) for transonic flows at the German Aerospace Center in Göttingen. He received his doctoral degree in 1997 from the University of Göttingen. Currently, he works as a researcher in the field of PSP applications for low-speed flows.

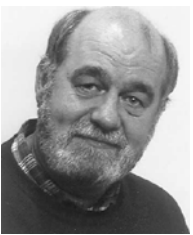

Rolf H. Engler: In 1969 he received his Dipl. Ing. degree at the Ing.-Academy of Wolfenbüttel in the field of air conditioning. After three years in industry, he started a study at the University of Göttingen and received his Dipl.-Physiker degree in 1979 for vortex investigation using Ultrasonic pulses. In 1986 he received the Dr. rer. nat. degree for experimental investigations of vortex breakdown using a newly developed non intrusive technique - the Ultrasonic-Laser-Method. He was still engaged to develop nondisturbing methods for flow field and surface investigations and temperature measurements. Since 1991 he works on pressure-sensitive paint techniques PSP in different wind tunnels of DLR and Europe. Since 1995 he is the project leader of the PSP team at DLR Göttingen and created with his team a DLR-PSP-Intensity system for various speed ranges as well as the PSP-Lifetime technique.